



## **DENALI Plow Mount MA11732 Kawasaki Mule**

Thank you for purchasing our DENALI plow mount. You now own a premium custom plow mount to allow you to use your plow with your SxS. Please note the following instructions and heed all warnings.

- Your UTV/SxS and/or plow system can cause death or injury, please use caution and common sense when operating your unit.
- Read your Plow Operator Manual, your Winch Operator Manual, and all warning labels before operating your UTV/SxS.
- Operate your UTV/SxS at a walking speed with the blade installed. Do not exceed 5 mph (8 km/h), even with the blade up.
- Do not operate the UTV/SxS on slopes greater than 10 degrees with the plow installed.
- Always lower the plow to the down position before leaving your UTV/SxS unattended.

**SEVERE INJURY OR DEATH MAY RESULT IF YOU ARE NEGLIGENT.**

**Kawasaki Mule  
MA11732**



**motoalliance**

22000 Industrial Blvd, Ste 250  
Rogers, MN 55374  
866.527.7637

**Please verify that all hardware and parts are included in your package.**

**Kit Contents:**

<b>Item Number</b>	<b>Quantity</b>	<b>Part Number</b>
1	1	MA11732 Plow Mount
2	2	10mm x 30mm Hex Bolts (1.25 thread)
6	2	10mm Flat Washers
3	4	3/8" x 1" Hex Bolts
4	4	3/8" Nylock Nuts
5	8	3/8" Flat Washers

### **Kawasaki Mule Installation Instructions**

1. Remove front plastic bumper guard.
2. Attach plow mount to the front of your UTV per Figure 1.
3. Remove front center skid plate bolts and retain the nuts to reuse.
4. Slide plow mount onto front end with the back portion of the mount going between the front bracket and on top of the skid plate mount bracket.
5. Use the 10 mmx30mm hex bolts and nuts retained on the back portion of the mount.
6. Next, line up the hole in the front and secure with 4-3/8" x 1" hex bolts, washers and Nylock nuts.
7. Tighten all bolts and replace the front plastic bumper guard.
8. The push tubes will hook up to the tabs on the mount with the quick release pins.

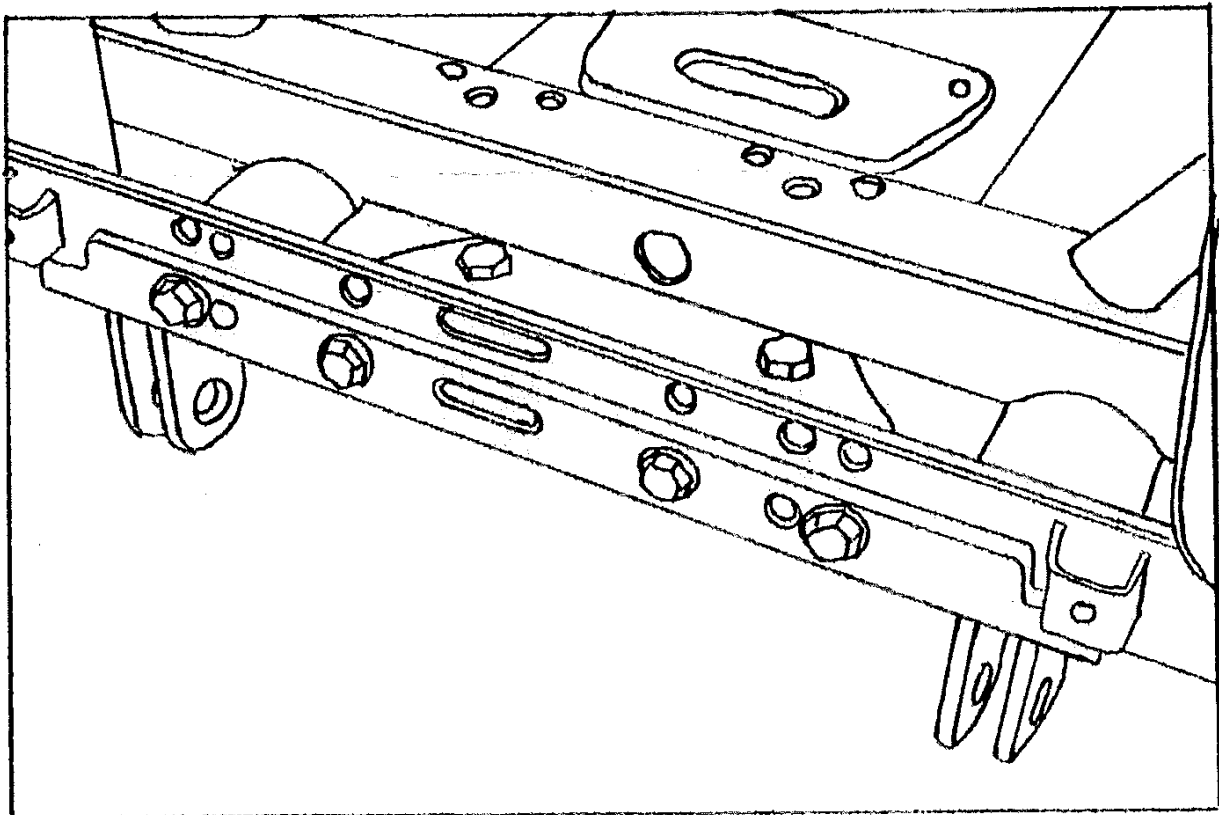

**Figure 1**